

Article number: 2302169098

Description: E+G Stjernegreb VCRT.50 FP-M8

Measures

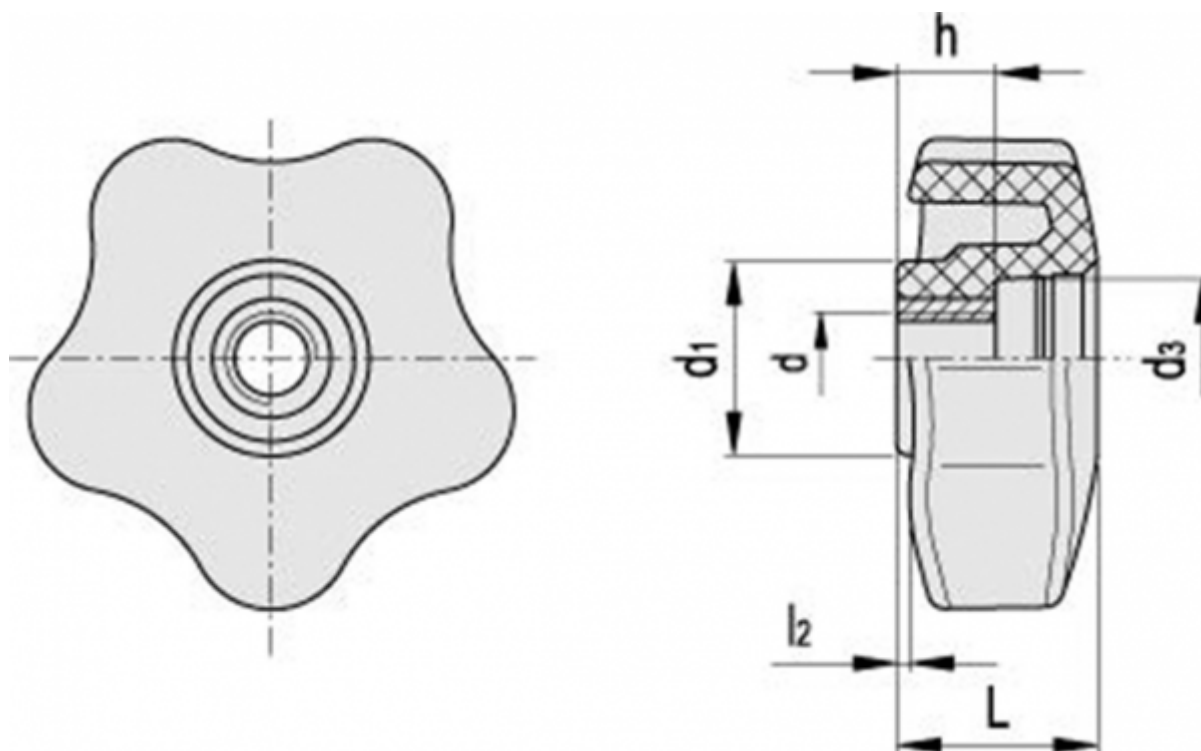

D	= 50
d1	= 19
d3	= 15.5
dh	= 8
h	= 10
l2	= 1.2
L	= 20
Weight in (g)	= 23